

TECHNICAL PARAMETERS

Model PSM - without the coil (30 L - 100 L)

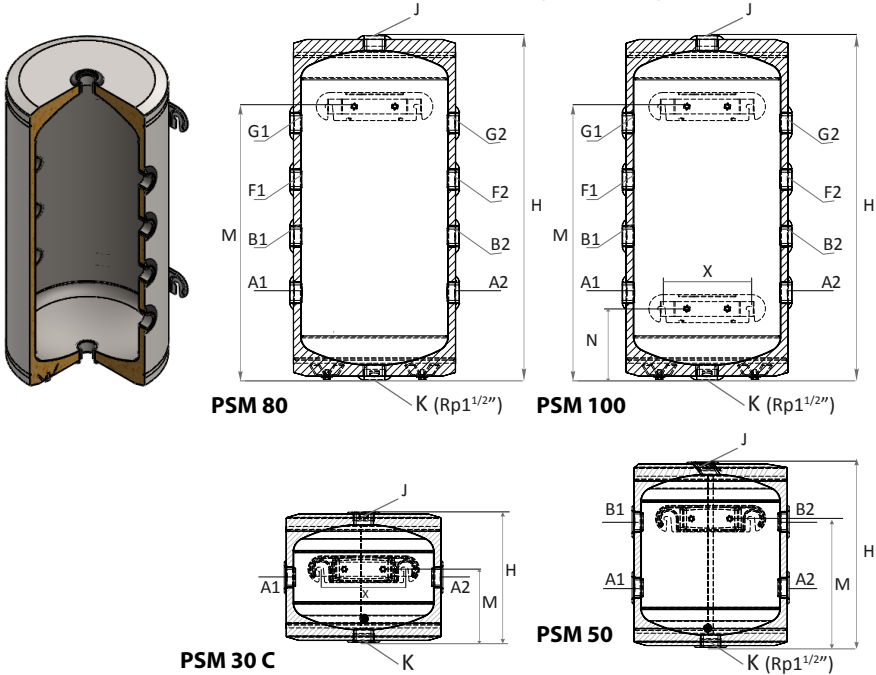

		PSM 30 C	PSM 50	PSM 80	PSM 100
Capacity	L	30	50	80	100
Height without feet	H, mm	360	520	755	915
Diameter with insulation	D, mm	∅ 440	∅ 440	∅ 440	∅ 440
Operating pressure/Max. buffer temperature	bar/°C	6/95	6/95	6/95	6/95
Weight	kg	13	17	25	29
Connection	A1**, A2** mm	Rp1" 180	Rp1 ^{1/2} " 170	Rp1 ^{1/2} " 190	Rp1 ^{1/2} " 230
Connection	B1, B2 mm, Rp1 ^{1/2} "	-	355	315	380
Connection	F1, F2 mm, Rp1 ^{1/2} "	-	-	440	535
Connection	G1, G2 mm, Rp1 ^{1/2} "	-	-	570	690
Connection	J**, mm	Rp1/2" 360	Rp1 ^{1/2} " 520	Rp1 ^{1/2} " 755	Rp1 ^{1/2} " 915
Connection	K** mm	Rp1/2"	Rp1 ^{1/2} "	Rp1 ^{1/2} "	Rp1 ^{1/2} "
Dimensions	N, mm	-	-	-	160
Dimensions	M, mm	230	365	595	760
Distance between suspension holes of the wall mount	X, mm,	240	240	240	240
Feet for floor mounting		-	✓	✓	✓

** for model PSM 30 C