

# Sludge separators

## DN 25...300



Sludge separators continuously remove smallest dirt particles without significantly increasing the flow resistance. A strong magnet retains magnetite. When the magnet is pulled out, the magnetic particles fall into the sump and be rinsed out via a ball valve without interrupting operation.

For central heating and cooling systems with closed circuits. For operation with non-aggressive, harmless fluids.

### Function

The sludge separator contains a wire mesh and a magnet inside the housing. Dirt particles are slowed down by the wire mesh and sink to the bottom. Magnetic particles are additionally held by the magnet. A flow direction for the medium is not specified.

### Technical data

Nominal sizes	DN 20...40 (horizontal) DN 20...25 (vertical) DN 50...300 with flanges																																				
Variants	With internal thread according to EN 10226 With flanges according to EN 1092-1 PN 16 With flanges according to ANSI Class 150																																				
Operating temperature	-10...110 °C																																				
Operating pressure	With internal thread or flanges according to EN 1092-1 PN16: max. 16 bar / PN 16 With flanges according to ANSI Class 150: max. 20 bar																																				
Medium	Heating and cooling water according to VDI 2035 or ÖNORM 5195 Water / Water-glycol mixtures with max. 50% glycol content																																				
Kvs values	<table border="0"> <tr> <td>DN 20</td> <td>10.7</td> <td>DN 50</td> <td>72</td> </tr> <tr> <td>DN 25</td> <td>17.2</td> <td>DN 65</td> <td>121</td> </tr> <tr> <td>DN 32</td> <td>31.8</td> <td>DN 80</td> <td>158</td> </tr> <tr> <td>DN 40</td> <td>40.0</td> <td>DN 100</td> <td>244</td> </tr> <tr> <td></td> <td></td> <td>DN 125</td> <td>351</td> </tr> <tr> <td></td> <td></td> <td>DN 150</td> <td>487</td> </tr> <tr> <td></td> <td></td> <td>DN 200</td> <td>780</td> </tr> <tr> <td></td> <td></td> <td>DN 250</td> <td>1,185</td> </tr> <tr> <td></td> <td></td> <td>DN 300</td> <td>1,696</td> </tr> </table>	DN 20	10.7	DN 50	72	DN 25	17.2	DN 65	121	DN 32	31.8	DN 80	158	DN 40	40.0	DN 100	244			DN 125	351			DN 150	487			DN 200	780			DN 250	1,185			DN 300	1,696
DN 20	10.7	DN 50	72																																		
DN 25	17.2	DN 65	121																																		
DN 32	31.8	DN 80	158																																		
DN 40	40.0	DN 100	244																																		
		DN 125	351																																		
		DN 150	487																																		
		DN 200	780																																		
		DN 250	1,185																																		
		DN 300	1,696																																		

# Dimensions

## With internal thread

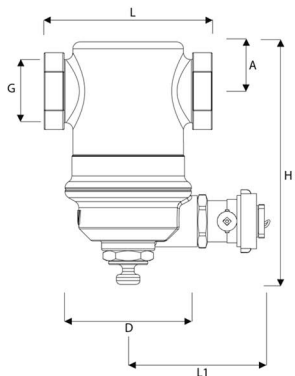

DN 20 to DN 40, for horizontal installation position

DN	G	L	L1	H	A	D	M <sup>1</sup>
<b>20</b>	Rp 3/4	85	73	123	25	64	130
<b>25</b>	Rp 1	88	73	138	35	64	130
<b>32</b>	Rp 1 1/4	88	73	158	40	64	130
<b>40</b>	Rp 1 1/2	88	73	188	40	64	175

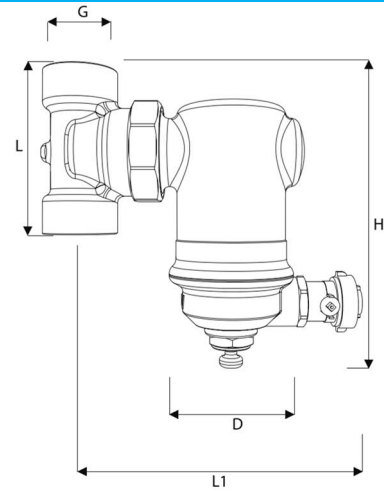

DN 20 and DN 25, for vertical installation position

DN	G	L	L1	H	D	M <sup>1</sup>
<b>20</b>	Rp 3/4	84	152	153	64	130
<b>25</b>	Rp 1	84	152	153	64	130

## With flanges

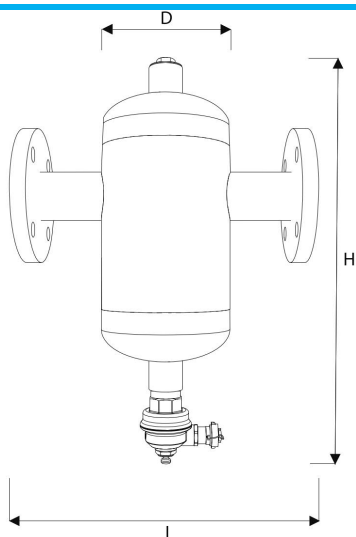

DN	D [mm]	H <sup>2</sup> [mm]	L [mm]	Weight <sup>3</sup> [kg]	Volume [l]	M <sup>1</sup> [mm]
<b>50</b>	159	506	350	17	7	250
<b>65</b>	159	506	350	20	7	250
<b>80</b>	219	637	470	31	18	300
<b>100</b>	219	637	475	35	18	300
<b>125</b>	325	859	635	59	51	—
<b>150</b>	325	859	635	65	51	—
<b>200</b>	408	1,101	775	90	114	—
<b>250</b>	508	1,301	890	140	214	—
<b>300</b>	612	1,502	1,005	238	307	—

<sup>1</sup> To be able to remove the magnet, a free space is required under the sludge separators up to nominal size DN 100.



<sup>2</sup> Approximate data

<sup>3</sup> Empty weight. Weight increases when filled with water.

## Materials

Component	Sludge separators with internal thread	Sludge separators with flanges
Body	Brass	Steel
Wire mesh	Copper	Copper
Draining device	Brass	Brass
Plug	—	Brass
O rings	FPM	FPM

## Item numbers

	Nominal size	Connection size	Item no.	Item no.
With internal thread			Horizontal installation position	Vertical installation position
	DN <b>20</b>	Rp 3/4	1124006	1124106
	DN <b>25</b>	Rp 1	1124008	1124108
	DN <b>32</b>	Rp 1 1/4	1124010	
	DN <b>40</b>	Rp 1 1/2	1124012	
With flanges			EN <b>1092-1 PN16</b>	ANSI Class <b>150</b>
	DN <b>50</b>	<b>2"</b>	1124550	1124650
	DN <b>65</b>	<b>2 1/2"</b>	1124551	1124651
	DN <b>80</b>	<b>3"</b>	1124552	1124652
	DN <b>100</b>	<b>4"</b>	1124553	1124653
	DN <b>125</b>	<b>5"</b>	1124554	1124654
	DN <b>150</b>	<b>6"</b>	1124555	1124655
	DN <b>200</b>	<b>8"</b>	1124556	1124656
	DN <b>250</b>	<b>10"</b>	1124557	1124657
DN <b>300</b>	<b>12"</b>	1124558	1124658	

## Accessories

Thermal insulation shells  
for horizontal installation position

	Suitable for	Item no.
	DN 20...25	1124091
	DN 32...40	1124092

for vertical installation position

	Suitable for	Item no.
	DN 20...25	1124091

# Pressure loss chart

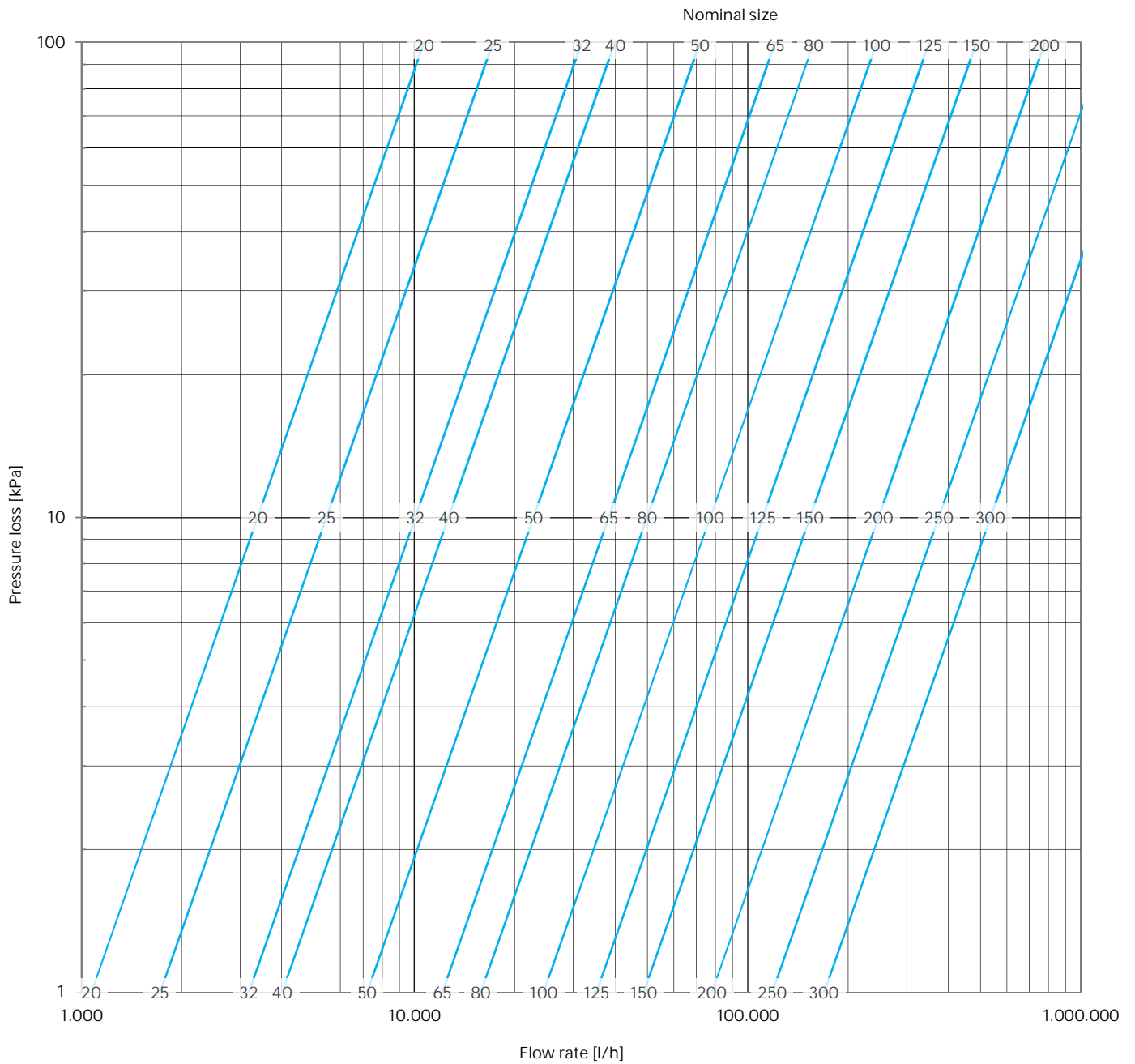

Subject to change • All rights reserved • © 2022 Oventrop GmbH & Co. KG  
 EN-05003-11240-DB-V2240 – October 2022