

Composite multifunction device with dirt separator and strainer *DIRTMAGPLUS®*



01258/24 EN

5453 series



Function

The DIRTMAGPLUS® multifunction device consists of two separate components arranged in series: a dirt separator and a replaceable strainer.

The presence of these two components allows for continuous protection of the generator and devices from any impurities that form in the hydraulic circuit both at the time of system start-up and in normal operating conditions.

The impurities are first separated by the dirt separator and then collected in a large dirt collection chamber from which they can be discharged even when the system is running.

Ferrous impurities are also trapped inside the body of the device thanks to the action of the two magnets inserted in a special removable outer ring.

By means of mechanical selection, the mesh strainer completes the process of removing the present impurities, starting directly from the first passage. DIRTMAGPLUS® can be adjusted for horizontal, vertical and 45° installation and it is supplied complete with shut-off valves to facilitate maintenance procedures.



Product range

5453 series DIRTMAGPLUS® composite multifunction device with dirt separator and strainer, with threaded connections _____ sizes DN 20 (3/4"), DN 25 (1") and DN 32 (1 1/4")

5453 series DIRTMAGPLUS® composite multifunction device with dirt separator and strainer, with olive fittings _____ sizes DN 20 (Ø 22) and DN 25 (Ø 28) with fittings for copper pipe

Technical specifications

Materials

Device body:	PA66G30
Dirt separator cover:	PA66G30
Top plug:	brass EN 12164 CW614N
Drain screw:	brass EN 12164 CW614N
Locking nut for device fitting tee:	PPSG40
Internal element:	HDPE
Impurity collector:	POM
Strainer:	POM - stainless steel EN 10088-2 (AISI 304)
Hydraulic seals:	EPDM
Drain cock	
with hose connection:	brass EN 12165CW 617N
Shut-off valves:	brass EN 12165 CW617N

Performance

Medium:	water, glycol solutions
Maximum percentage of glycol:	30 %
Maximum working pressure:	3 bar
Working temperature range:	0-90 °C
Ring system magnetic induction:	2 x 0,3 T
Initial cleaning strainer mesh size (blue):	0.30 mm
Maintenance strainer mesh size (grey):	0.80 mm
Device internal volume:	0,4 l (DN 20 - DN 25) 0,53 l (DN 32)

Connections

Body:	3/4", 1" F, 1 1/4" (ISO 228-1) Ø 22 and Ø 28 mm for copper pipe
-------	--

Dimensions

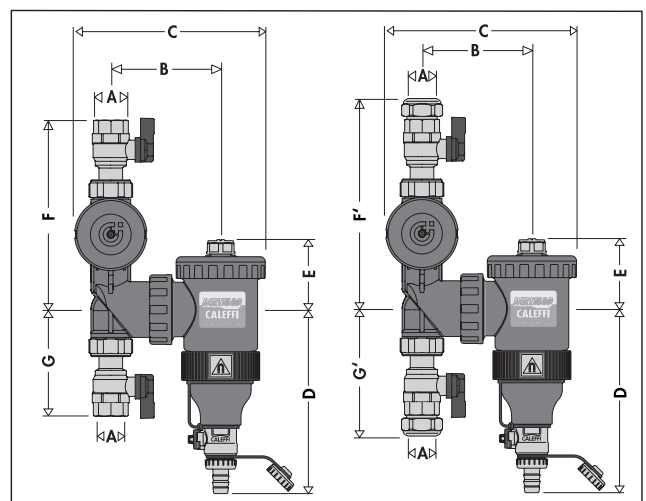

Code	DN	A	B	C	D	E	F/F'	G/G'	Mass (kg)
545375	20	3/4"	106,5	182	172,5	65,5	178	101	1,9
545376	25	1"	106,5	182	172,5	65,5	182	105	2,0
545377	32	1 1/4"	106,5	182	172,5	65,5	193,5	116,5	2,3
545372	20	Ø 22	106,5	182	172,5	65,5	186	287	2,0
545373	25	Ø 28	106,5	182	172,5	65,5	190	293	2,0

Problems caused by impurities in hydraulic circuits

The components of a heating and cooling system are exposed to degradation caused by the impurities contained in the system circuit. If the impurities in the thermal medium are not removed, they can impair operation of the units or components, such as the heat exchangers in generators, especially during the system commissioning stage, from the very first passage. This latter problem must not be underestimated because boiler manufacturers will frequently reject warranty claims if their product is not adequately protected by a strainer from the time of commissioning onwards. Currently the dirt separators and strainers present on the market are unable to guarantee

protection of the components in any stage of operation. It is therefore necessary to use a multifunction device that can overcome all these problems by efficiently removing debris particles in all working conditions.

1. The removal of particles - even those with small diameters (sizes of a few hundredths of a millimetre) - is handled by the dirt separator through the effect of the particles colliding with the internal element and the **decanting of sludge due to gravity** in the collection chamber. This result can be obtained only after some circulations of the medium and hence during operation of the system in steady-state conditions.

2. The total elimination of particles with diameters measured in tenths of a millimetre, **from the very first passage of the medium** (system commissioning), is guaranteed by the mesh strainer, which mechanically intercepts impurities carried by the thermal medium.

The effectiveness of the strainer action comes with significant pressure drops and the need to clean the strainer mesh frequently. This makes it necessary to provide a rapid maintenance system or even the option of removing the strainer to limit pressure drops after the initial flushing stage.

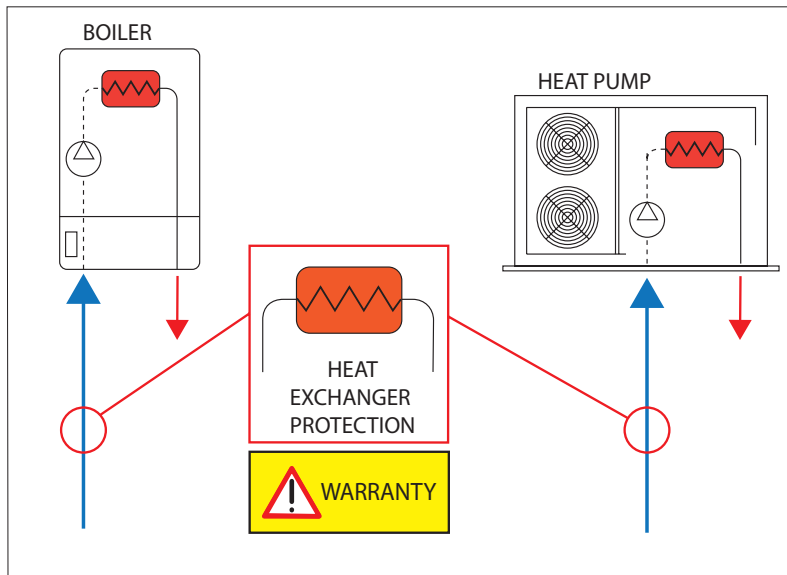

Operating principle

The operating principle of the multifunction device is based on the combined action of two separate components arranged in series:

1. A dirt separator (1), which **separates** impurities contained in cooling systems.

The internal element (2) of the dirt separator consists of a set of radial reticular surfaces. On striking these surfaces the impurities in the water are separated out, dropping into the bottom of the body (3) where they are collected. Ferrous impurities are also trapped inside the dirt separator body, thanks to the action of the two magnets (4) inserted into a special removable outer ring. The large internal volume of the dirt separator slows down the flow speed of the medium thus helping, by gravity, to separate the particles it contains down to sizes in the region of one thousandth of a millimetre.

2. A replaceable cartridge strainer (5) that mechanically **intercepts** the impurities contained in the thermal medium.

The cartridge strainer intercepts impurities by means of mechanical selection of the particles in accordance with their size, by means of a special metal mesh.

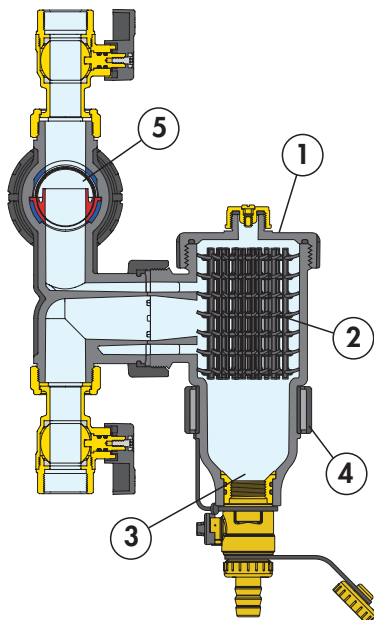

The water circulating in the system flows, in sequence, first through the dirt separator (1) and then through the cartridge strainer (5). The first passage through the dirt separator makes it possible to separate a high percentage of the impurities in the circulating water, down to minimal particle sizes. The medium then flows through the strainer in which 100 % of the remaining particles with a diameter greater than the mesh size are intercepted mechanically. The dirt separation action reaches peak efficiency after the thermal medium has been recirculated a few times, up to the nominal operating phase of the system.

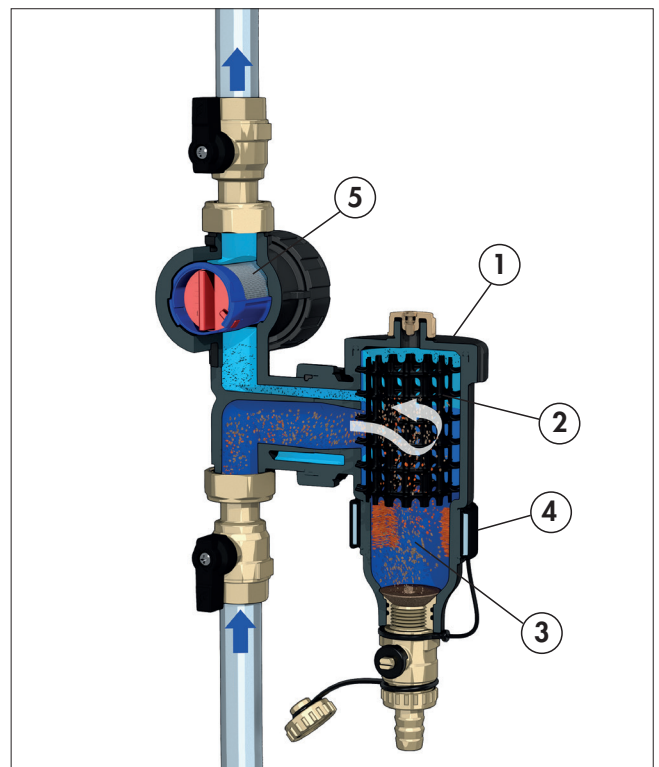

Construction details

Cartridge strainer

The high-capacity strainer cartridge consists of two parts: an outer body (6 or 8) with stainless steel mesh and a specially shaped internal element (7) for collecting impurities. The complete collection of impurities is always optimal, whether installation is vertical, horizontal, or at 45°.

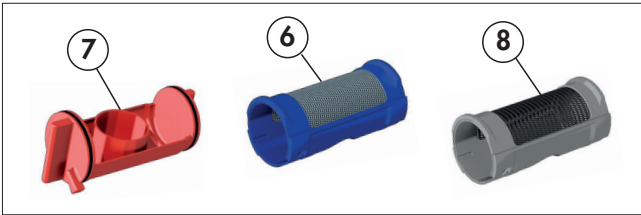

The blue strainer supplied consists of a metal mesh with a filtration capacity capable of capturing particles with a diameter greater than 0,3 mm. This specific strainer mesh is able to intercept all particles remaining in circulation, thereby ensuring optimal initial cleaning of the pipes. After shutting off and draining the DIRTMAGPLUS® device, the strainer (6) can be easily inspected as follows:

- removal to clean the strainer of the impurities it has captured and that have accumulated in the dirt collector (7);
- replacement with a maintenance strainer (grey colour) (8) (filtration capacity such as to capture particles with a diameter greater than 0,8 mm);
- if appropriate, the multifunction device can function as a simple dirt collector by removing the supplied strainer.

Strainer accessible from both sides of the enclosure

The two closing plugs on each side (9) of the strainer enclosure (10) facilitate its extraction in accordance with the installation position of DIRTMAGPLUS®.

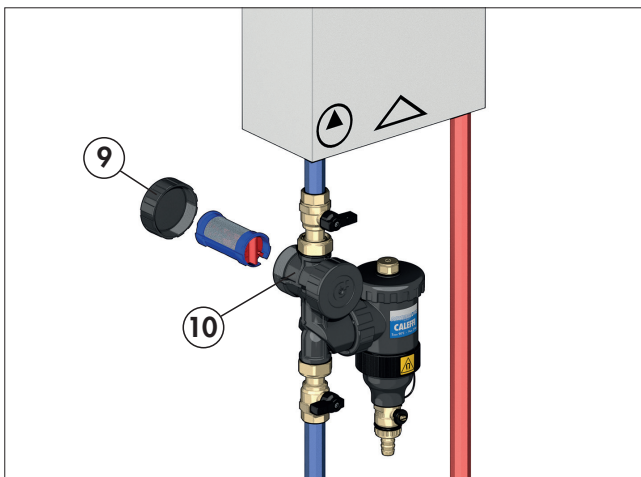
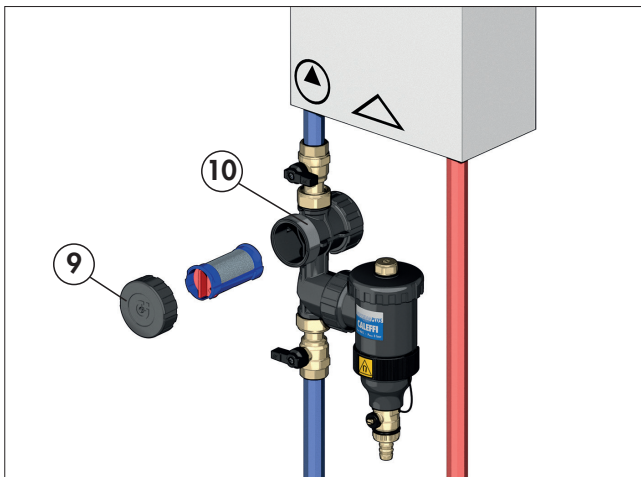

Adjusting the body to horizontal and vertical pipes

Thanks to the special coupling of the tee fitting and locking nut, DIRTMAGPLUS® can be adjusted (fig.1) so that it can be fitted on vertical pipes (fig. 2), horizontal pipes (fig. 3), or 45° angled pipes, without affecting its functional characteristics.

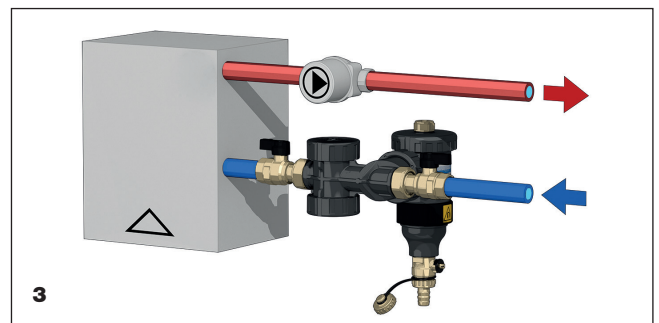
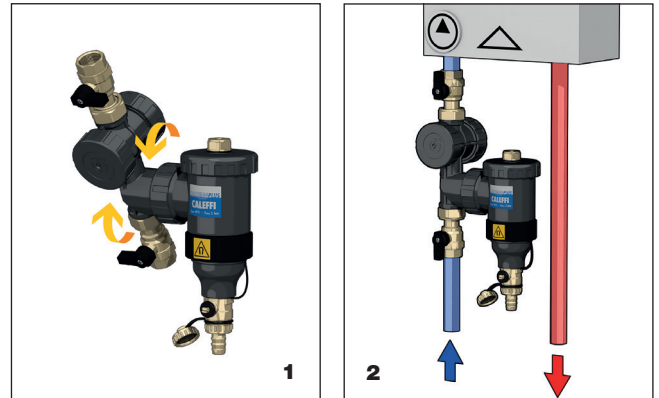

Multifunctionality and practicality in reduced space

DIRTMAGPLUS® is a compact device designed to take up the minimum amount of space and to offer practicality and versatility for installation, maintenance and potential use for circuit filling and flushing procedures.

Shut-off valves

To facilitate inspection and maintenance tasks the multifunction device is equipped with two shut-off valves (11) that allow the device to be not only isolated but also completely emptied by way of the drain cock (12).

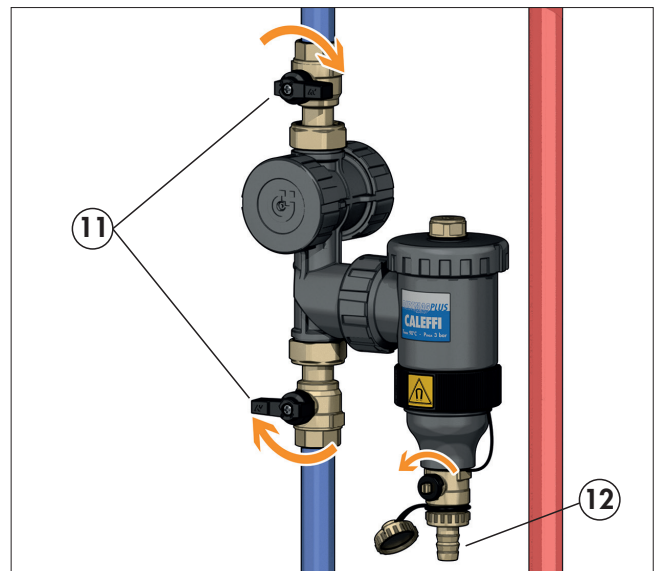

Composite

The dirt separator strainer is made using a composite material specifically selected for heating and cooling system applications. The main features of the composite are:

- high strain strength while maintaining good ultimate elongation.
- good resistance to crack propagation.
- very low humidity absorption, for consistent mechanical behaviour.
- high resistance to abrasion caused by continuous medium flow.
- consistent performance as temperature varies.
- compatibility with glycols and additives used in circuits.

These basic material characteristics, combined with the appropriate shaping of the most highly stressed areas, allow a comparison with the metals typically used in the construction of dirt separators.

Low pressure drops and performance maintained over time

The high performance of the dirt separator is based on the use of the internal element with mesh surfaces. The principle of collision and decantation of particles makes the dirt separation action more efficient if compared to common strainers. This performance is constant over time, unlike common strainers which instead get clogged by the trapped sludge, thus altering their functional features.

Separation of ferrous impurities

This series of dirt separators, fitted with a magnet, offer greater efficiency in the separation and collection of ferrous impurities. The impurities are trapped inside the dirt separator body by the strong magnetic field created by the magnets fitted in the special outer ring.

The outer ring can also be removed from the body to allow their decantation and subsequent expulsion while the system is still running. Since the magnetic ring is positioned outside the dirt separator body, the hydraulic characteristics of the device are not altered.

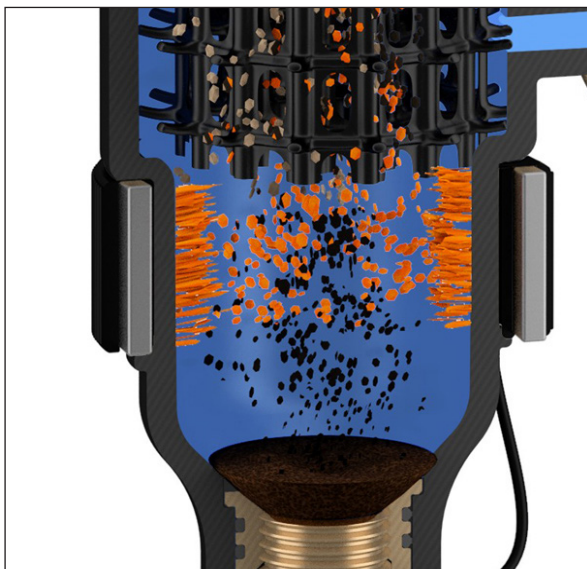

Geometric structure and large dirt collection chamber

The dirt collection chamber has the following features:

- it is located at the bottom of the device, at such a distance from the connections that the collected impurities are not affected by the swirling of the flow through the mesh;
- it is large enough to increase the amount of collected dirt, which means emptying/discharging procedures are required less often (in contrast to strainers, which need to be frequently cleaned);
- it is easy to inspect, by unscrewing the top cap from the valve body for any maintenance of the internal element required in the event of clogging by fibres or large dirt particles.

Accessory kit

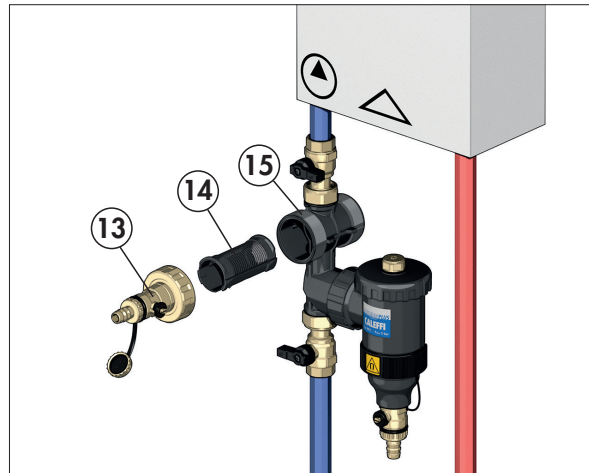

Accessory kit (optional, code F49476) for filling and flushing the circuit consists of a plug with a drain cock (13) and a black coloured element (14) to be fitted in the strainer enclosure (15) to separate the flows.

This kit can be used to connect an external system filling/flushing machine (16) in compliance with specific commissioning regulations and procedures.

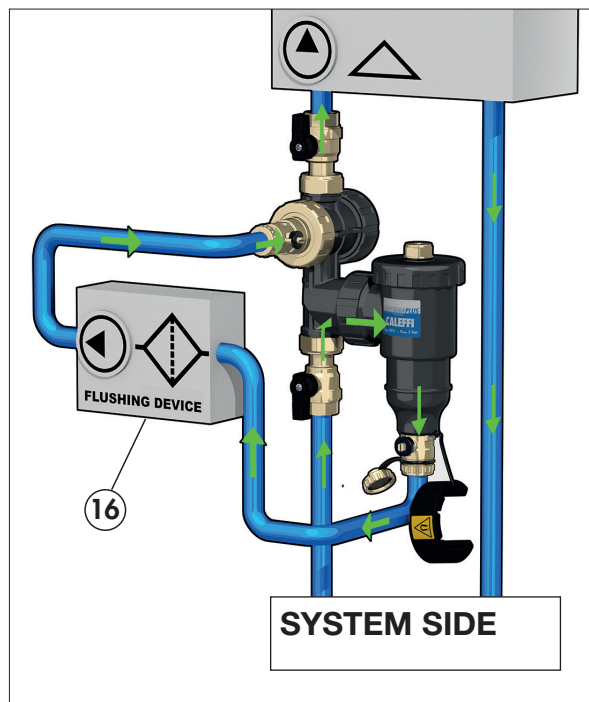

Additive dispensing



The multifunction device can also be used as an access point for injecting chemical additives designed to protect the system into the circuit.

Hydraulic characteristics

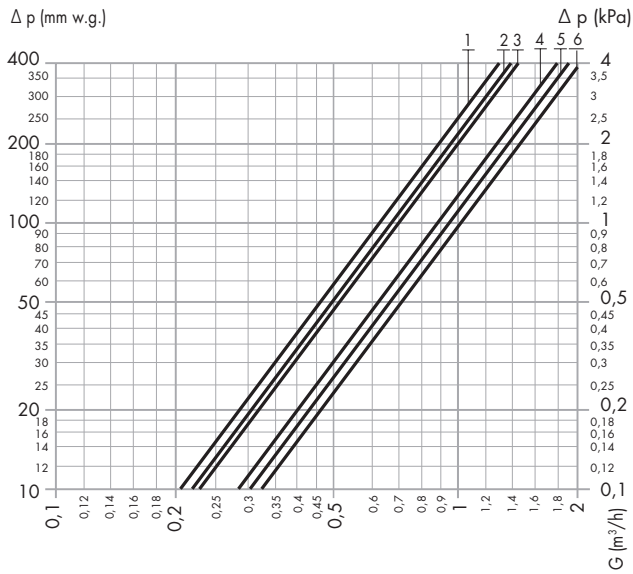

	Kv (m ³ /h)		Kv (m ³ /h)	
	1	2	3	4
Device with blue strainer	6.3	8.9	4	6.7
Device with grey strainer	6.7	9.6	5	7.0
Device without strainer	7.0	10.5	6	8.9

The maximum recommended flow velocity of the medium at the device connections is ~1 m/s. The following table shows the maximum flow rates in order to meet this requirement.

DN	l/min	m ³ /h
20 - 25	18.8	1.13
32	30.0	1.80

Installation

The multifunction device must be installed in accordance with the flow direction indicated by the arrow on the tee fitting and, preferably, on the return circuit upstream of the generator. It must always be installed in a vertical position, with the air vent facing upwards, and preferably upstream of the pump.

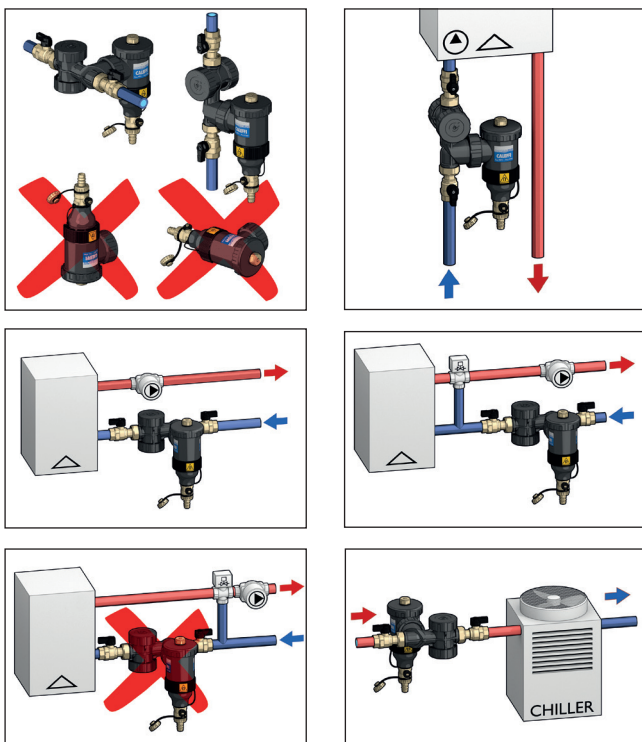

Air vent

Use a screwdriver (17) or a butterfly key (18) to undo the screw on the top cap in order to purge any air that has collected at the top of the body.

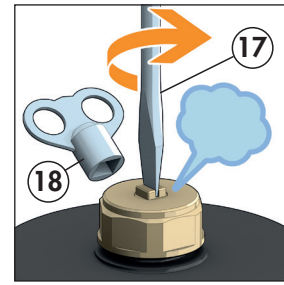

Strainer cleaning

Close the shut-off valves. Drain off the water contained within the device. Remove the strainer and rinse it under running water.

Sludge drainage

Remove the ring in which the magnets are housed (fig. 1) and drain the impurities, even while the system is running, using the special key provided (fig. 2).

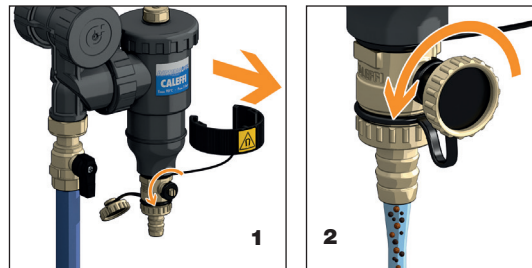

Maintenance

To carry out any maintenance work required for the dirt collection chamber, shut off the device using the relevant valves (11), drain the water from inside using the drain cock and unscrew the top cover (19) using the supplied key. Finally, remove the internal element (20).

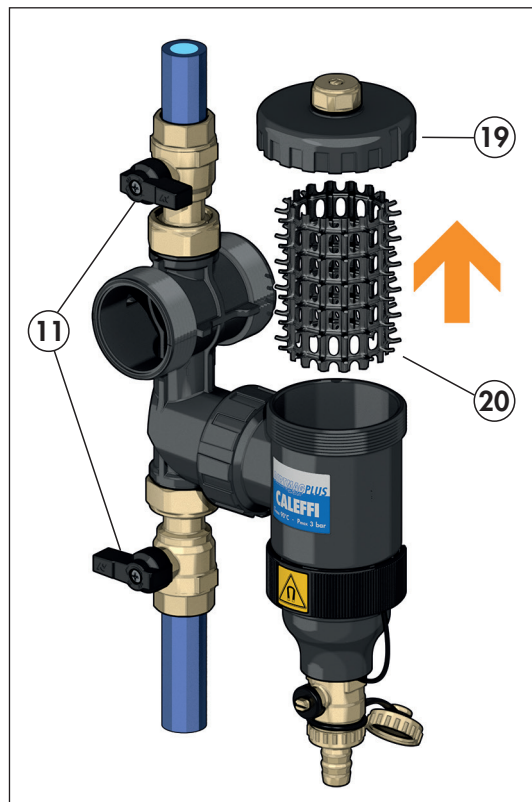

Accessories



Accessory kit for circuit filling and flushing for series 5453 device.

Code

F49476

Accessory strainers

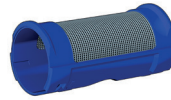

First cleaning strainer
Mesh size Ø = 0,30 mm



Maintenance strainer
Mesh size Ø = 0,80 mm

Code

F49474/BL cleaning strainer (blue)

F49474/GR maintenance strainer (grey)

Application diagram

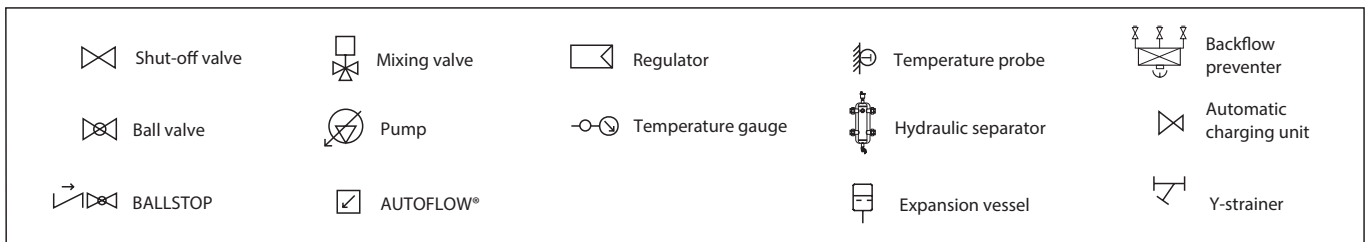
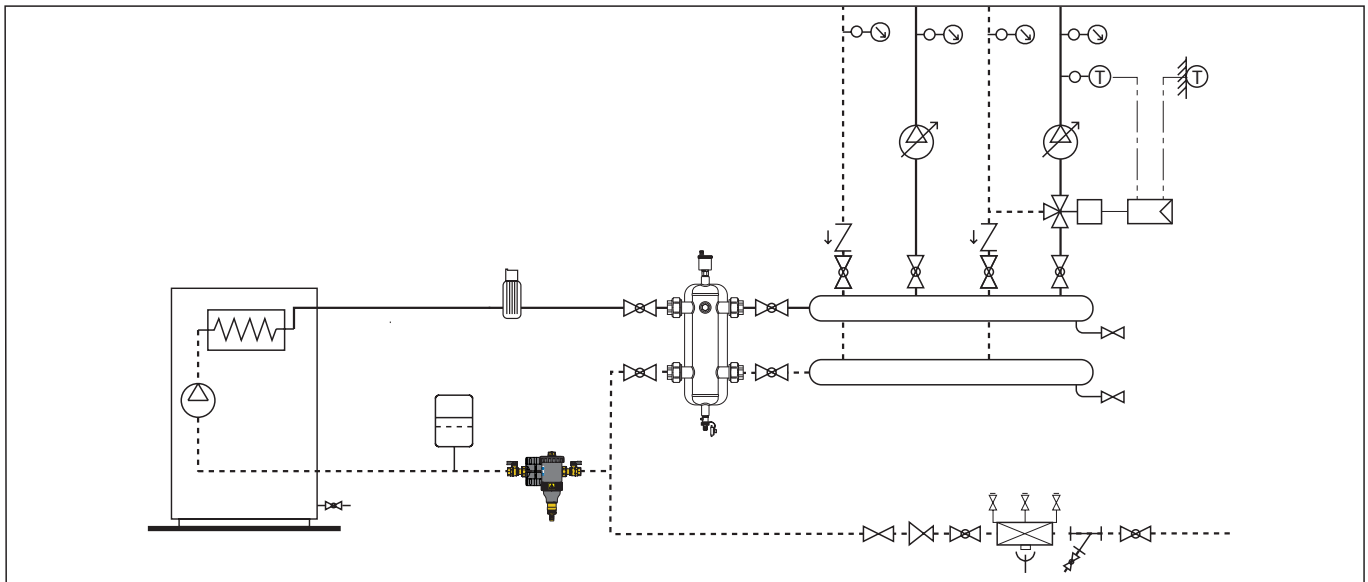

SPECIFICATION SUMMARY

DIRTMAGPLUS® 5453 series in composite material

Multifunction device with dirt separator and strainer. Dirt separator with magnet. DN size 20 (and DN 25, DN 32). Adjustable 3/4" (and 1", 1 1/4") F connections (ISO 228-1). PA66G30 body and cover. HDPE internal element. EPDM hydraulic seals. Locking nut for tee fitting in PPSG40. Shut-off valves and drain cock with brass hose connection. Dirt collector in POM, strainer in POM and stainless steel. Medium water and glycol solutions; max. percentage of glycol 30 %. Maximum working pressure 3 bar. Working temperature range 0–90 °C. Strainer mesh size Ø 0,30 mm (initial cleaning), Ø 0,30 mm (maintenance). Device internal volume 0,4 l. PCT INTERNATIONALPATENT APPLICATION.

DIRTMAGPLUS® 5453 series in composite material

Multifunction device with dirt separator and strainer. Dirt separator with magnet. DN size 20 (and DN 25). Adjustable connections with olive fittings for Ø 22 mm (and Ø 28 mm) copper pipe. Shut-off valves and drain cock with brass hose connection. PA66G30 body and cover. HDPE internal element. EPDM hydraulic seals. Locking nut for tee fitting in PPSG40. Shut-off valves and drain cock with brass hose connection. Dirt collector in POM, strainer in POM and stainless steel. Medium water and glycol solutions; max. percentage of glycol 30 %. Maximum working pressure 3 bar. Working temperature range 0–90 °C. Strainer mesh size Ø 0,30 mm (initial cleaning), Ø 0,30 mm (maintenance). Device internal volume 0,4 l. PCT PCT INTERNATIONAL PATENT APPLICATION.

We reserve the right to make changes and improvements to our products and the related technical data in this publication, at any time and without prior notice. The website www.caleffi.com always has the most up-to-date version of the document, which should be used for technical verifications.