

**12. ELECTRIC WATER HEATER BB NL2 V/EL - 80 L, 100 L, 120 L, 150 L, 200 L.
Electric (without coil). Vertical models.**

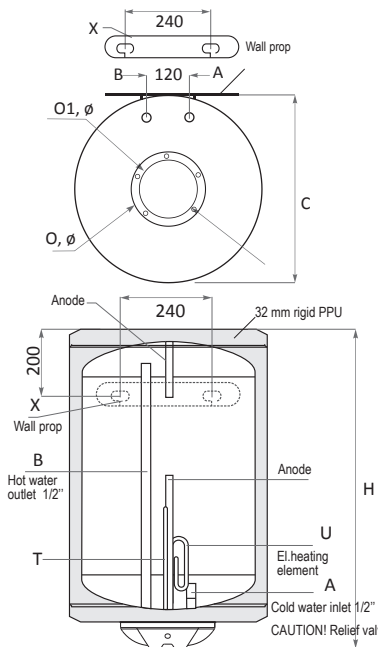

BB NL2 V/EL 80-150 L

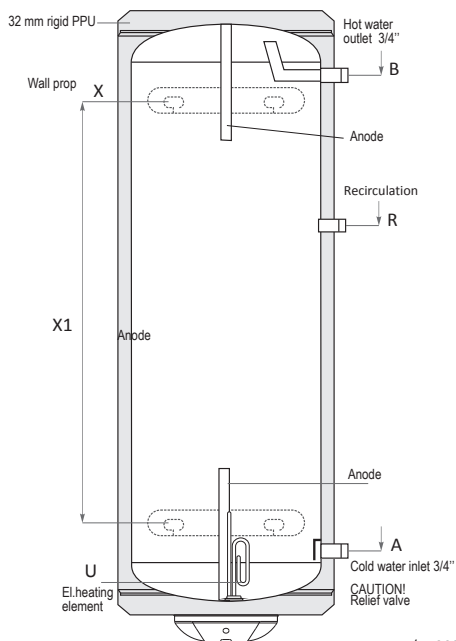

BB NL V/EL 200 L

		BB NL2 V/EL 80	BB NL2 V/EL 100	BB NL2 V/EL 120	BB NL2 V/EL 150	BB NL 2 V/EL 200
Capacity	L	80	100	120	150	200
Height	H, mm	685	815	945	1085	1355
Diameter	D, mm	ø 520	ø 520	ø 520	ø 520	ø 520
Insulation	mm	rigid PPU, thickness 32 mm.				
Oper. pressure / max. temperature	MPa(bar)/°C	0.8(8)/95	0.8(8)/95	0.8(8)/95	0.8(8)/95	0.8(8)/95
Test pressure of tank	MPa(bar)	1.3(13)	1.3(13)	1.3(13)	1.3(13)	1.3(13)
Electric heating element (optional)	kW	2/3	2/3	2/3	2/3	2/3
Weight	kg	38	42.2	50	56	68
Cold water inlet	A, mm	Rp 1/2"	Rp 1/2"	Rp 1/2"	Rp 1/2"	Rp 3/4" 170
Hot water outlet	B, mm	Rp 1/2"	Rp 1/2"	Rp 1/2"	Rp 1/2"	Rp 3/4" 1120
Recirculation	R, mm					Rp 3/4" 877
Inspection opening/Flange	O, O1, mm	ø 132/90	ø 132/90	ø 132/90	ø 132/90	ø 132/90
Anode	P1, P2	✓/✓	✓/✓	✓/✓	✓/✓	✓/✓
Thermostat	T	✓	✓	✓	✓	✓
Wall prop/ Distance between both stands	X1, mm				630	900